



## Technical comercial data

# E-5.5 T.E-5.5-O

Serie ELEGANCE – Versión 07-02-2024

Lid with screw shutter cap

### TECHNICAL DATA:

Material:	PP copolymer of first quality, suitable for contact with food according to current regulations.
Colours:	White standard. Consult for other colours.
Useful Volume:	5.5 litres
Volume to the edge:	6.5 litres
Weight of the bucket:	203 g. approx.
Weight of the lid (with berg):	101 g. approx.
Weight of the handle (plastic):	8 g. approx.
Total Weight:	312 g. approx.
Decorative surface flat inks:	127 x 637 mm (height x perimeter)
Design surface photographic finish:	135 x 650 mm (height x perimeter)



### MEASUREMENTS:

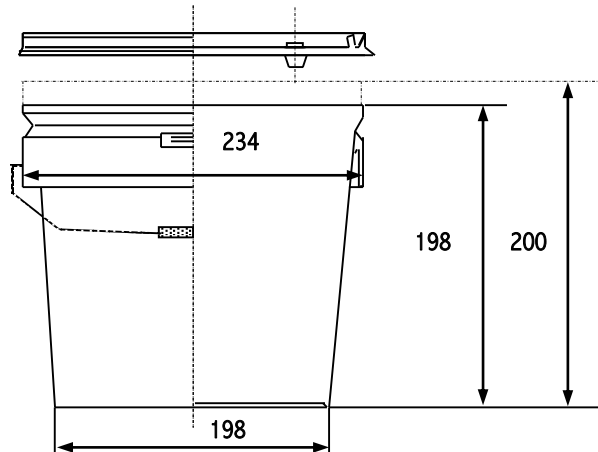

Measurements in millimetres

### GROUPING OF TRANSPORT:

Buckets:	600 buckets per pallet
Pallet dimensions:	1180 x 950 x 1140 (see drawing)
Lids:	100 lids per box, this serves as a packaging of transportation
Box dimension:	480 x 240 x 800

